

MOSQUITO

Ultra-Sonic Teenage Crowd Dispersal System

The Mosquito is a non-invasive device that has been specifically designed to disperse groups of teenagers who may be loitering in areas where they could prove to be a nuisance. It is an effective deterrent that causes no physical pain or damage, even in the event of long term exposure.



features :

The system generates a pulsed, near ultra sonic tone at around 16Khtz, close to the limit of the hearing range of people under 25 years of age. The sound, though not painful in any way, becomes highly annoying after 5 or so minutes exposure. The result is that most under 20s leave the immediate area, whilst the majority of those over the age of 30, because of natural age related hearing loss, either just hear, or, as in most cases, are totally unaware of any noise at all.

- Automatic or manual triggering
- The unit incorporates a 20 minute cut off timer to avoid unnecessary annoyance
- Robust vandal / weatherproof housing
- Complies with the HSE 2005 guidelines and is already widely used by police and local authorities around the UK

MOSQUITO

ULTRA-SONIC

Crowd Dispersal System

DIMENSIONS :

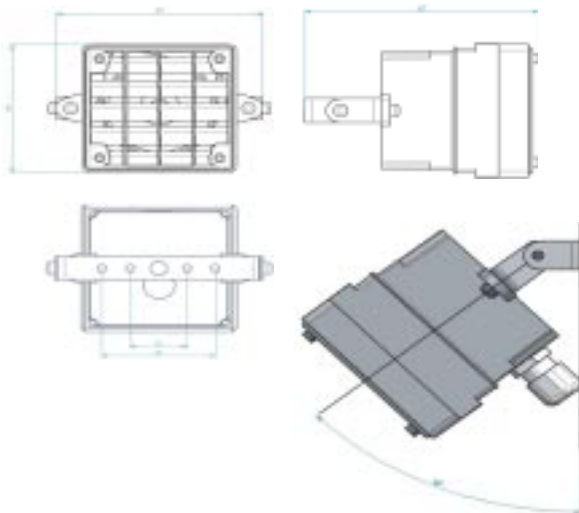

SPECIFICATIONS :

VOLTAGE

12Vdc

TONES

Single tone above 16KHz

SOUND OUTPUT

High and low setting with automatic ambient compensation

COMPENSATION

Output is automatically increased to be 5 to 8dB above the ambient, up to the maximum for each setting

OPERATION

Setting 1 - Tone operates for 20mins then silences and awaits retrigger

Setting 2 - Tone operates continuously until switched off

ACTIVATION

Mode 1 - Alarm operates at power on

Mode 2 - Alarm operates in response to external trigger (PIR etc.)

Mode 3 - Alarm operates in response to built-in vox switch (noise activation)

PROTECTION

Vandal and weather resistant IP65 enclosure suitable for external use

TEMPERATURE

-20° to +70°C

MATERIAL

Diecast zinc alloy and steel

MOUNTING

Wall mounting, angle bracket available

COLOUR

Grey

For more information about Mosquito, to view documented police, local authority and SME's field test results or to place an order, contact our Marketing Department

telephone: +44 (0)870 7575 400 fax: +44 (0)1594 545 445

email: marketing@coopersecurity.co.uk

Cooper Security, Security House, Vantage Point Business Village, Mitcheldean, Gloucestershire, GL17 0SZ. UK
www.coopersecurity.co.uk

Part No. 11690974

DEALER ADDRESS DETAILS :